



The MARSHALL Company
Church Furniture of Distinction



President's Message

Is any labor too good for the house of the Lord? At The Marshall Company, we've always considered our work with something greater than personal pride. From the very first pew built in 1936, we've always felt our craft must reflect our faith: functional, beautiful and enduring.

That's why we still pride ourselves on being one of the few companies still making a quality solid wood pew: no veneers, no chipboard cores, no plastic laminates, only the classic beauty and durability of true Northern Red Oak: a wood as solid as our commitment to craftsmanship.

The quality of the furnishings in any church reflects the depth and inner strength of that congregation's faith. We are proud to be able to offer you the highest quality for your furnishing dollar. We have furnished churches of all denominations throughout the Western United States and invite you to visit churches in your area where Marshall furniture is installed. It's simply the best way to learn of the lasting beauty, quality and performance of our work: a work we take very seriously and present sincerely — as unto the Lord.



Page One:
St. Matthew's Episcopal Church
Pacific Palisades, California
Moore Ruble Yudell Architects

Sunnyside Seventh Day Adventist Church
Portland, Oregon
Petersen, Kolbert & Associates, Architects



Over Half a Century of Service

For over fifty years The Marshall Company has offered distinctive church furnishings throughout the western United States and parts of Canada. Our reputation and continued success is a testimony of our commitment to the many fine congregations we have served. Whether your church is new or undergoing renovation, we can offer you the same commitment to quality, innovative design, service and value.

Commitment to Quality

If you want to create a thing of lasting beauty, you must work a little longer and a little harder at it. For instance, the selection and processing of the choice Northern Red Oak for our pews takes over one entire year. Our unique methods of sanding, finishing and quality checking are no less impressive. At Marshall there are only "high" quality furnishings. While some pieces may be more or less expensive due to design considerations, every piece we manufacture is made with the same care and commitment to quality craftsmanship. We don't have to be so thorough with every piece we produce, but it's worth it . . . your solid oak is absolutely guaranteed not to warp, split or check and will contribute to the grace of your church for many, many years. When you take pride in your work, it shows!

Commitment to Innovative Design

The Marshall Company has never been one to rest upon the laurels of its success. In 1946 we introduced the acoustical spring pew. Even today this is the most comfortable and long-lasting pew on the market. Indeed, we built the first fully upholstered pews in America. And our recent open-ended Anniversary Pew is rapidly becoming a classic.

No job is too big or too small for our custom department's designers or craftsmen. Any piece or ensemble may be custom made to your specifications, including custom designed pew ends and chancel pieces. Even if you have a limited budget, our factory representatives can help you furnish your building with quality and elegant furnishings. More than just "order takers," they are experienced in listening to your needs and helping you coordinate our many comparable stock furnishings into a unique and quality interior setting.

Commitment to Service

The Marshall Company's commitment of service to our congregations is as solid as the Northern Red Oak we use in our pews. Since we do not use middlemen to complete our projects, we can guarantee complete satisfaction. Our factory representatives can be of

great service to your building or renovation plans. They can assist you in your selection of furnishings and ensure proper installation so you can enjoy the many years of beauty and service our furnishings provide. Our location in Payette, Idaho is a crossroads of the west, providing us with convenient, year-round routes to all of our service areas. We stand ready to serve your needs at any time.

Commitment to Value

Your own position in your church is a testament of your sound judgment and commitment to Christian values. The Marshall Company has shared in your commitment for over half a century. While it is your responsibility to choose a manufacturer who can furnish your house of worship in a manner worthy of your faith, it is our responsibility to provide the furnishings, craftsmanship and service worthy of your decision. We can also promise that you will receive furnishings of beauty and endurance that represent the most value for every dollar you spend — furnishings that will last the life of your building! The responsibility and commitment we both share in to furnish your church appropriately is one we take as seriously as you do.

*St. Andrew's Presbyterian Church
Newport Beach, California
C. Edward Ware
Irwin & Associates, Architects*



*Commitment to Quality,
Innovative Design, Value, and Service*



Calvary Community Church
Longview, Washington
Robert Chervenak & Associates, Architect

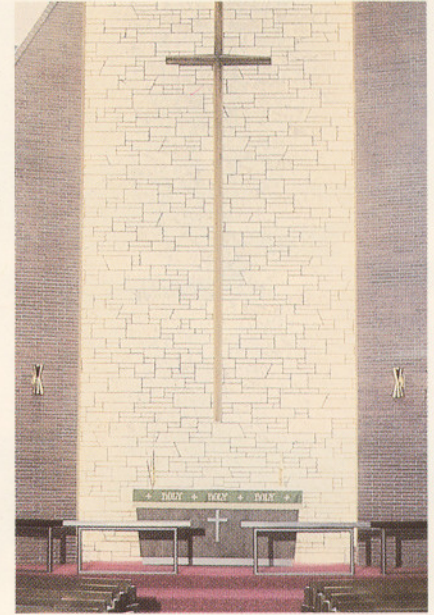

Faith Lutheran Church
Great Falls, Montana



Covina Assembly of God
Covina, California
Resource Architects



Hand-Carved Ambo
Holy Apostles Catholic Church
Colorado Springs, Colorado
Nakai/Paulson Architects



Side Chapel for St. Andrew's Presbyterian Church
Newport Beach, California
C. Edward Ware
Irwin & Associates, Architects



Waller Hall
Willamette University
Salem, Oregon
Settecase Smith Doss Architects



Mission San Juan Capistrano
San Juan Capistrano, California
John Bartlett, Architect



St. James Catholic Church
Seguin, Texas
Morkovsky Architects



*Knott Avenue Christian Church
Anaheim, California*



*Central Christian Church
Mesa, Arizona
Norman Bryar Architect*

Solid Oak & The Secret of Marshall Craftsmanship

How We Give You the Best Value for Your Furnishings Dollar — Anywhere!

Although there is no worthy substitute for a solid oak pew end, considerable time and expense must be spent in the effort to maintain this quality. Most other manufacturers either cannot or will not bear this cost, but at The Marshall Company, keeping our fine reputation intact is worth the price.

Only the Finest Timber

Our long journey to perfection begins in the Northern hill country of Pennsylvania where we carefully select our red oak a full year before its anticipated demand. The timber can only be sawn in the winter when the “sap is down,” then stacked carefully for cool air drying until the next summer so it won’t split or check. It is then kiln dried to exactly 6% moisture content before shipping. After receiving the lumber, we store it in a special humidistatically controlled warehouse for no less than three months to relieve the natural stresses and equalize all the boards.

The boards can now be cut, ripped and edge-glued with urea glue in our electronic gluing machine to produce blanks for laminating into pew ends. The glued blanks are then stacked and stored for at least 45 more days under humidity controlled conditions. This way each blank can become “compatible” with each other. We then surface (plane) the board and laminate the end blanks into one big, thick piece in a 50,000 pound hydraulic press.

It’s a lot of effort, but it’s the only way we can deliver perfect furnishings to our congregations . . . furniture absolutely guaranteed not to warp, split or check. NO thin veneer to chip or peel away — NO hidden softwood or low grade core-stock — NO chipboard — just honest Northern Red Oak through and through — as solid as your faith!

A Labor of Love

Just as we spare no effort in manufacturing solid oak pew ends, we also labor over the sanding and finishing of each piece. Then, to further

ensure your furniture will last a lifetime, we finish test each piece to the following standards:

Humidity Check — 1 hour at 95% RH @ 140 degrees, then dry at 70 degrees and 30 degrees RH. **Sun Test** — no less than 24 hours direct clear sunlight, surface 90 degrees to the sun. **Water Test** — 3 minutes in boiling water. **Wet Cloth Test** — a wet towel of 100 degrees temperature for 2 hours; dry at room temperature. **Heat and Cold Check** — no less than 6 cycles, 20 minutes each in an oven of 170 degrees and a freezer of -10 degrees.

OUR GUARANTEE: NO checking, peeling, discoloration, finish or grain raising shall be apparent. Not on delivery, not next year and not five years from now. Now that is value for your money.





Bel Air Presbyterian
Los Angeles, California
Moore Ruble Yudell Architects



Mission Hills Baptist
Littleton, Colorado
H.W.H.L. Associates Architects

Anniversary Edition

“Destined to become a classic”



Introduced with great pride in 1986 to celebrate our 50th anniversary, this innovative and luxurious pew is rapidly becoming a classic. No wonder! Our Anniversary Edition combines the best of our design and manufacturing capabilities acquired through our fifty years of distinctive service. Manufactured of the finest solid Northern Red Oak, this pew features the beauty of a flawlessly finished wood grain set off to perfection in a design unlike any other. A revolutionary open-ended styling gives it a distinctive contemporary feel that will easily complement a wide variety of interior arrangements. And while it has been designed for maximum use and durability, its soft, comfortable contours and upholstered seat and back, place it among the most comfortable pews ever created. Step up to the contemporary look, feel and durability of our Anniversary Edition!

Series 9250

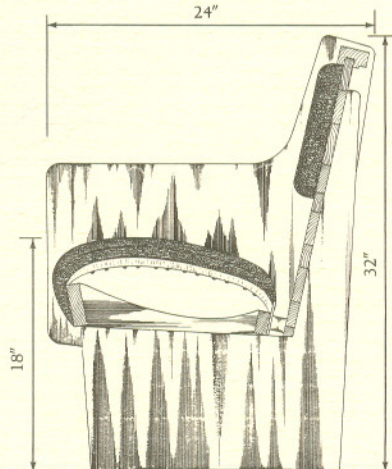

Series 9250

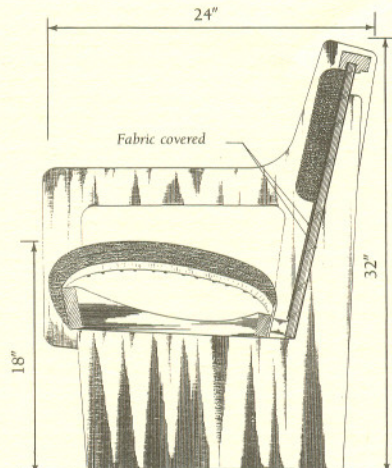

Series 9260

Custom Royal Pews

“Unsurpassed comfort & durability”

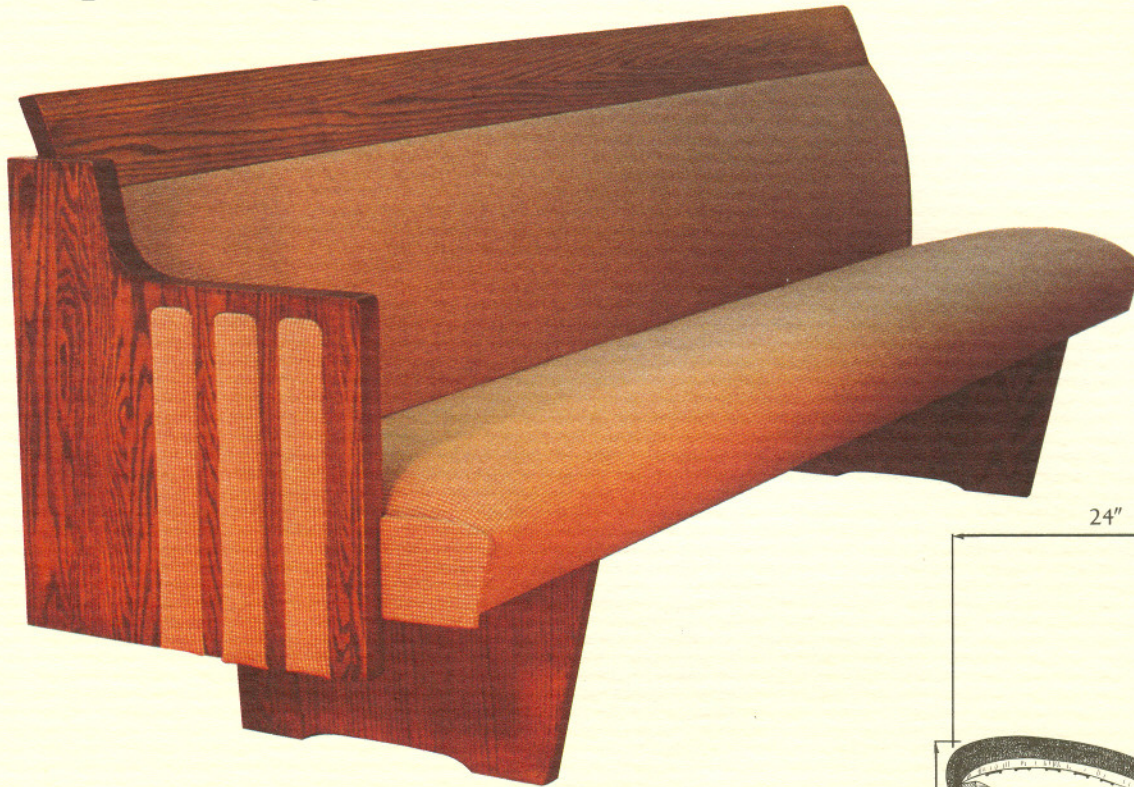

After five years of development, the 900 series has been in continuous production ever since 1946. Its continued popularity is due to the simple fact that this pew is the ultimate combination of comfort, utility and durability. Your congregation can worship in ease and comfort while enjoying its elegant, contoured back and wide caprails. Its simple but elegant design accents almost any decor. And as for durability — this pew enjoys the strongest frame in the industry with a spring design that prevents that “bottoming out,” so common in inferior pews after several years. All supports are anchored to the caprail for added strength and durability. The covers, of course, are of high quality and will last for many years. It is hard to go wrong when choosing this design — its beauty and elegance will grace your house of worship for many years!

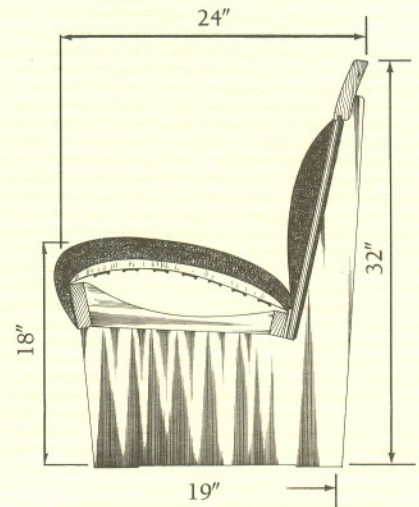

946 Pew Body

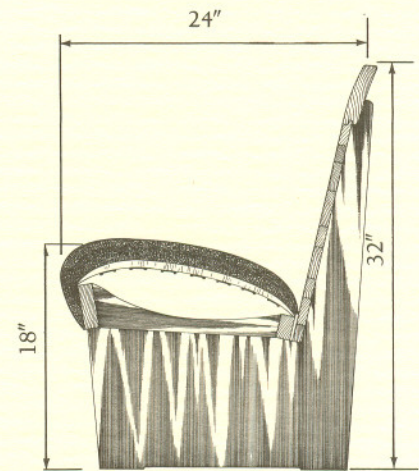

940 Pew Body

Detailed shop drawings and specifications available on request.

Series 900

Custom Padded Pews

"Simplicity & comfort . . . by design"

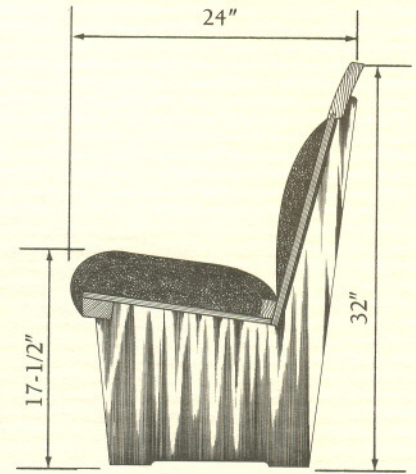

Series 846 Pew Body

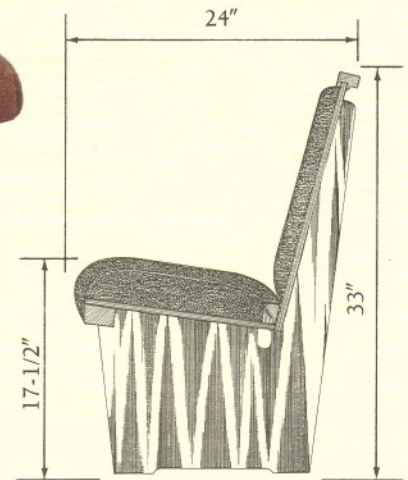

Series 825 Pew Body

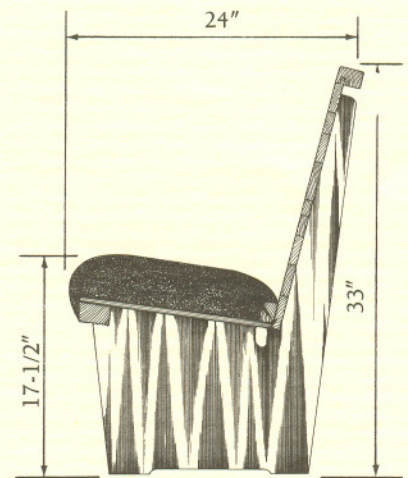

Series 820 Pew Body

Detailed shop drawings and specifications available on request.

Although of simpler design than our series 900 and 9250 pews, this long-time favorite features every bit of quality craftsmanship and enduring beauty that we build into all of our pews. A high quality, extra thick 2-ply polyurethane padding makes this pew much more comfortable than plain wooded varieties, and prevents those common "bottoming out" problems to give you many more years of service. This pew has been carefully engineered so many custom designs can be rendered through its interchangeable seats and backs, giving you the flexibility your worship environment may require.

Our series 846 pew features our exclusive wide shoulder roll caprail with a comfortably contoured foam on the backrest. Selected fabric coverings will add color and beauty to your church for years to come.

Series 800

“Custom Royal” Hardwood Pews

“The most comfortable hardwood pew ever made”



It takes special talent and expertise to craft a hardwood pew that is truly comfortable. Marshall's exclusive Custom Royal “shoulder roll” solid oak pew fits literally everyone. Whether you are tall or short, sit up straight or slouch, the “shoulder roll” provides you with comfort and support. Most curved or contour back pews fit only certain sizes or shapes of people — and then only when one sits up perfectly straight (which most of us don't do for very long!). Our “shoulder roll” design is the answer!

The combination of the solid oak “shoulder roll” cap rail and heavily molded seat (solid 1-1/2 inch thick oak) makes this pew the most comfortable hardwood in America. Marshall's Custom Royal Pews are always constructed from genuine, solid Northern Red Oak, certified as to origin and winter cut from trees selected especially for church furniture use.

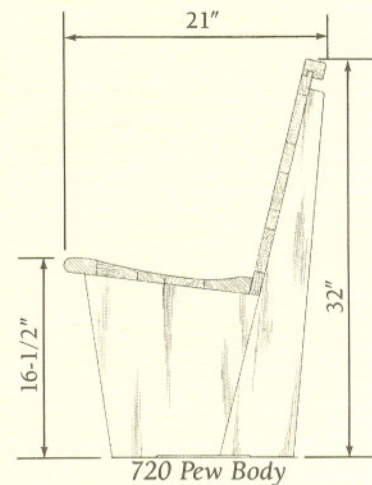
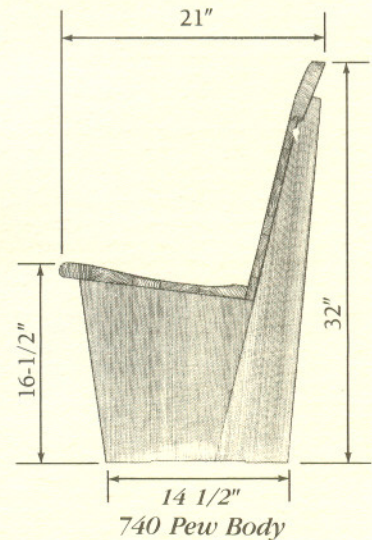

Detailed shop drawings and specifications available on request.

Series 700

Portable Pews

“When flexibility is required . . .”

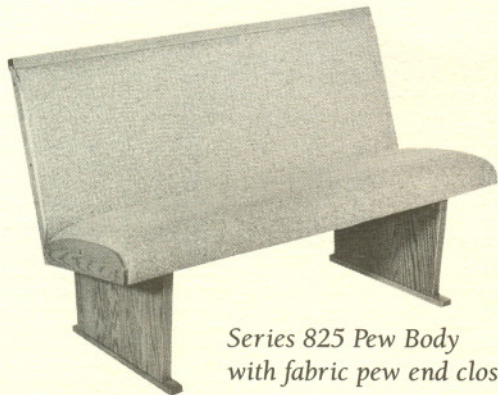

*Series 825 Pew Body
with fabric pew end closure*

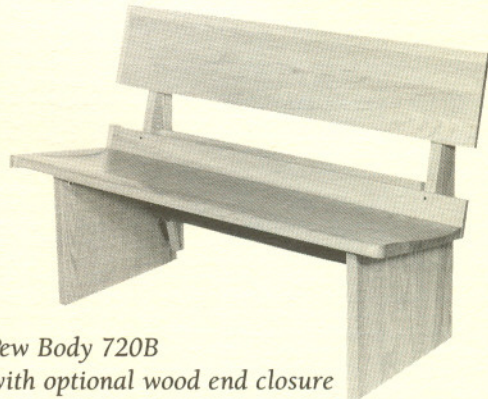

*Pew Body 720B
with optional wood end closure*

When your church has flexible seating needs, Marshall's Portable Pews are the answer. Combining the beauty of natural red oak with the comfort of upholstered, cushioned seats, these moveable units offer total flexibility in appearance, style, use, length, finishes and fabrics.

Illustrated here are just three of the possible liturgical seating arrangements with our portable pews. The pews are available in uniform sizes (up to 8 feet in length) or a combination of our three standard lengths (40, 60 or 80 inches). The flexibility of these pews makes them the answer to economical seating for multipurpose facilities, overflow areas, choir or chapel seating, temporary seating areas, or even permanent seating arrangements!

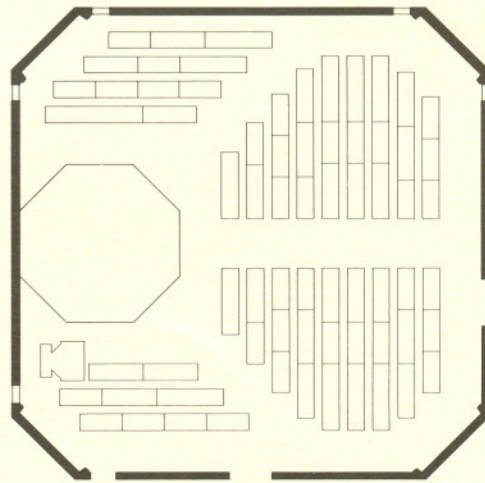

Processional Seating Plan

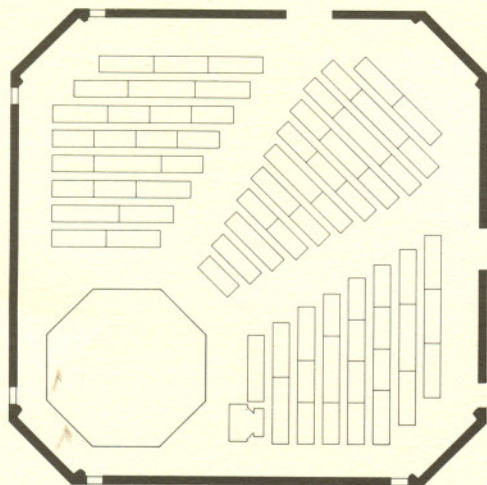

Prophetic Seating Plan

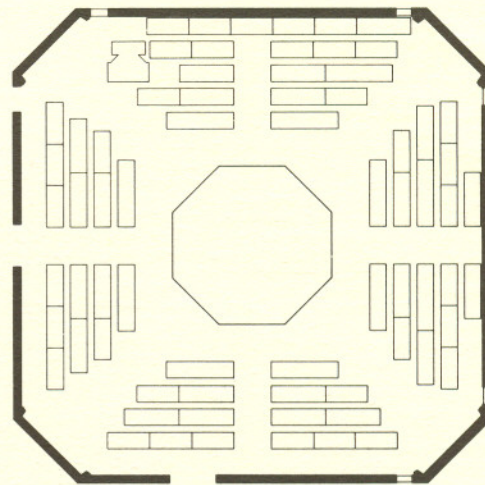

Sacramental Seating Plan

Marshallok Chairs

Superior Features

For maximum flexibility and practicality, the unique design of Marshallok Chairs cannot be matched. You can put their strength and beauty to work in place of pews, for choir seating, or as additional seating wherever needed. And, as with all Marshall products, only the finest oak is shaped into the uniquely-contoured frames of these chairs. Sturdy spline nail and brace construction, plus quality upholstery, add extra comfort and durability.



*Rush Seat
with Wood Back*

Arm Chair



Standard



Sled Base



Stackability

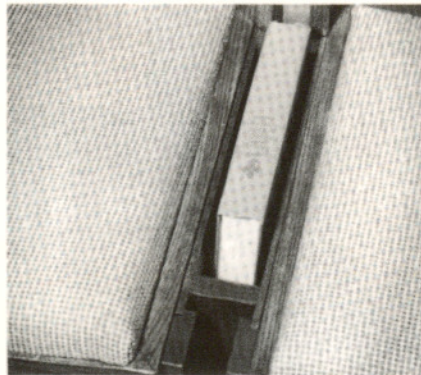

*Interlocking
Book Racks*



Kneeler Design

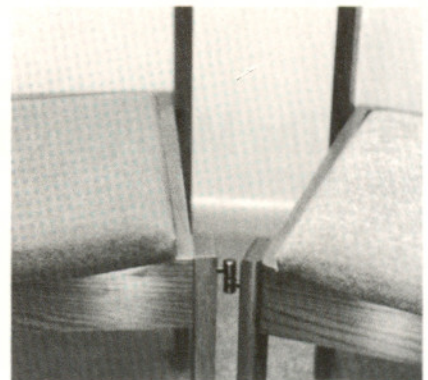

Radial Pivot

Solid Oak Pew Ends

"Excellent variety for any pew style"

As these illustrations indicate, we are experienced craftsmen with all types of pew ends and offer a wide variety for your selection. We can even make your own design into a piece of fine furniture. Whatever style you specify, you can be assured of the highest quality of materials and craftsmanship.

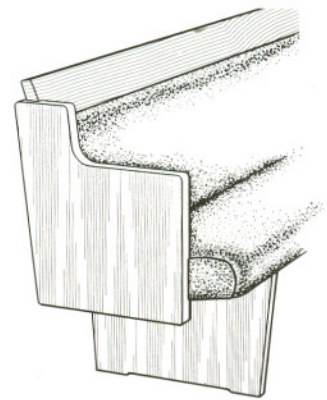

734-C

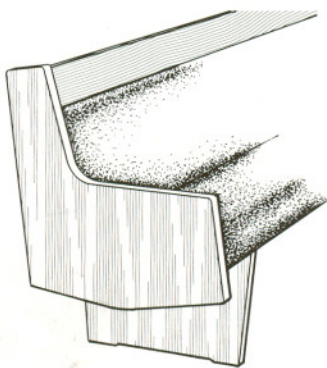

45-C

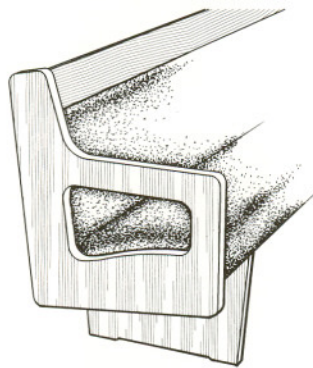

501-C

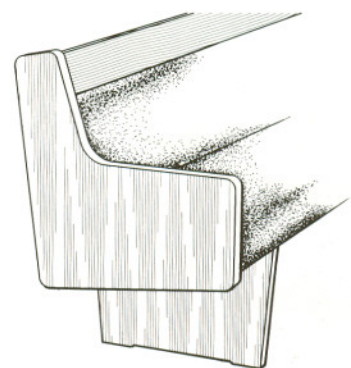

351-C

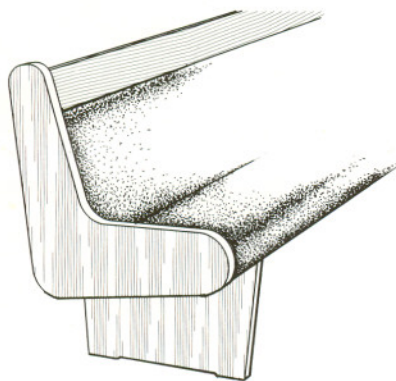

728-C

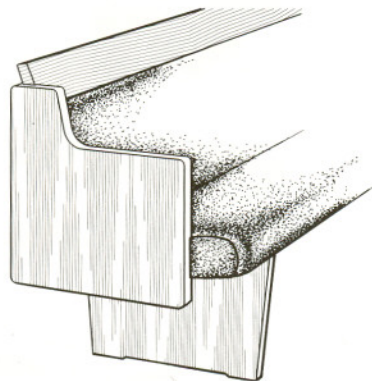

735-C

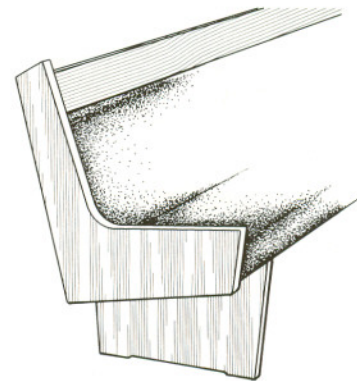

354-C

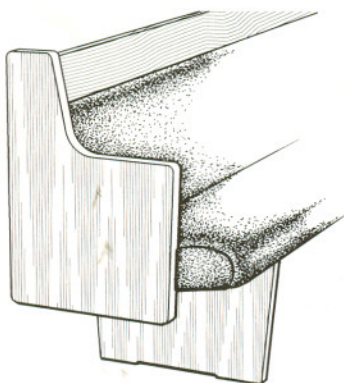

452-C

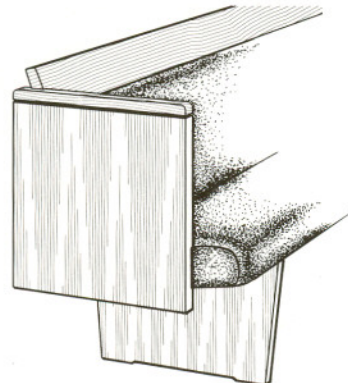

723-C

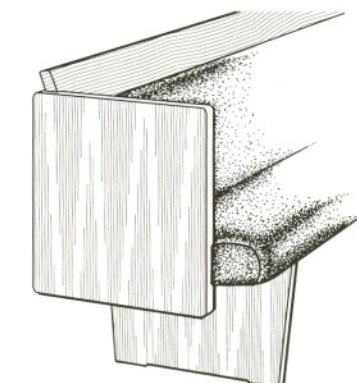

726-C

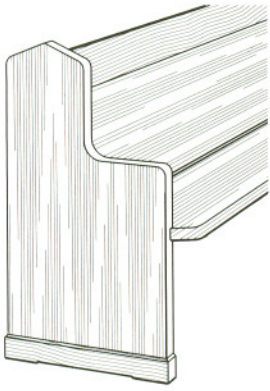

321

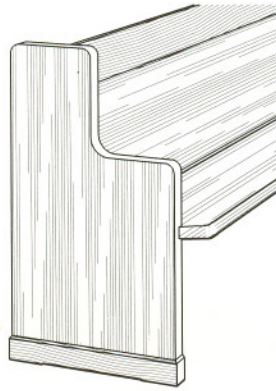

331

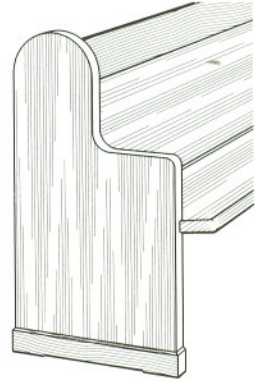

344

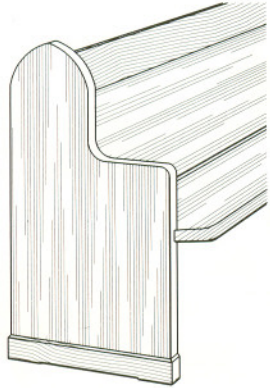

324

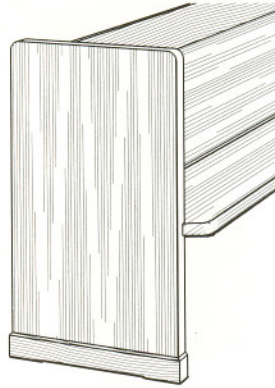

620

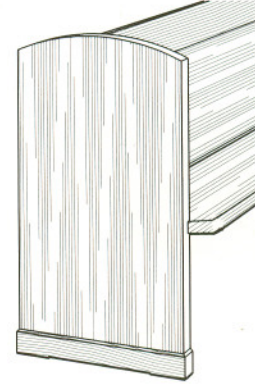

643

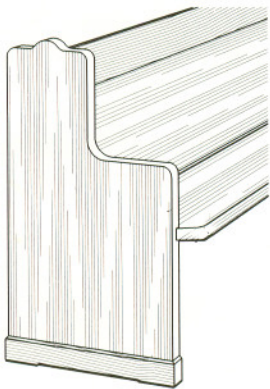

352

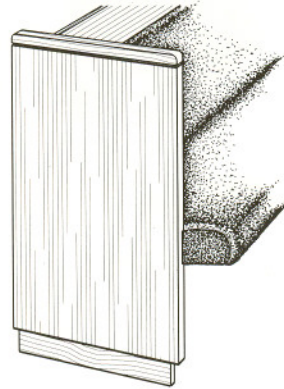

723-A

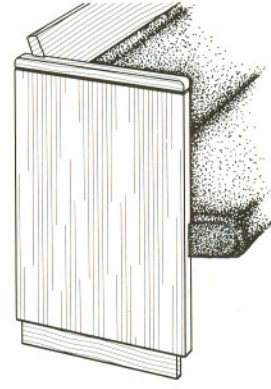

723-B

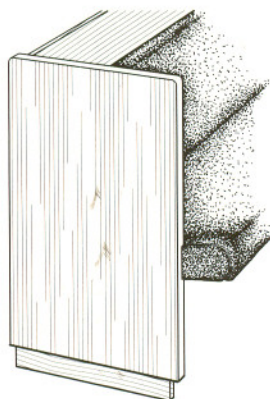

726-A

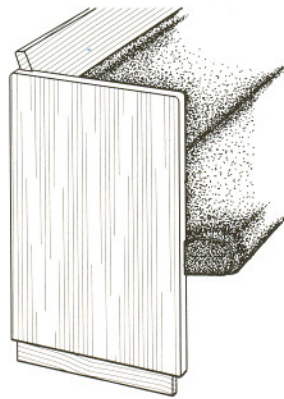

726-B

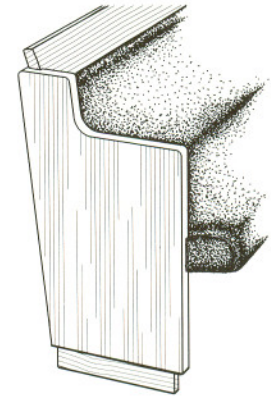

452

Pew Accessories

Kneelers

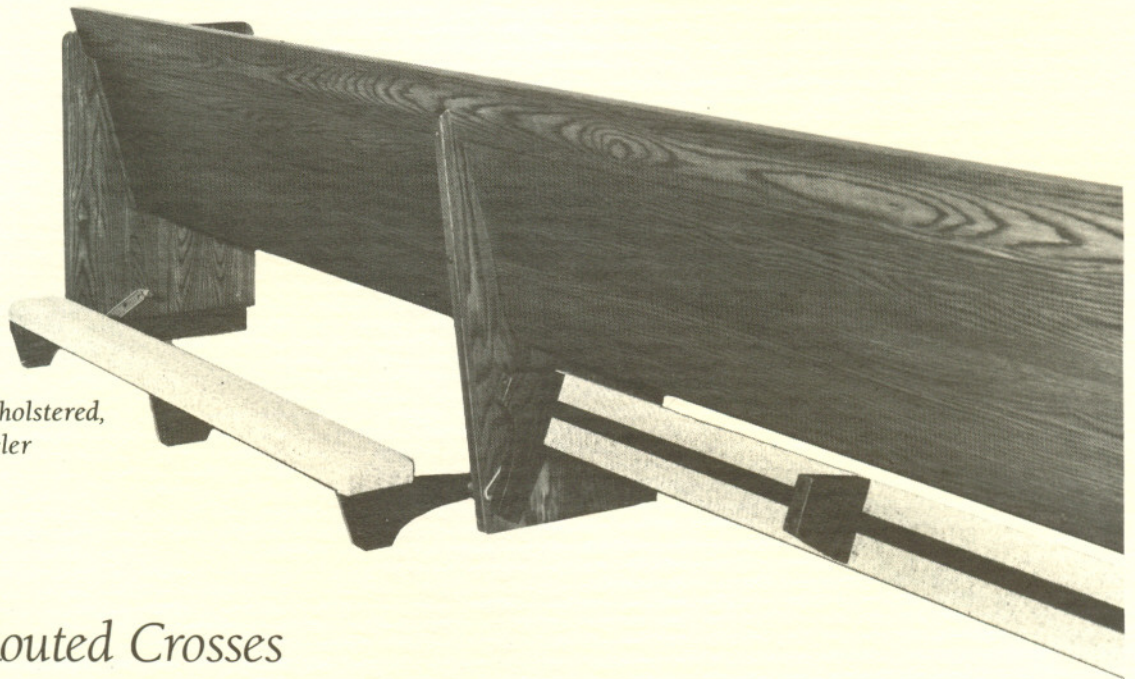

Deluxe, fully upholstered, wood trim, kneeler

Decorative Routed Crosses

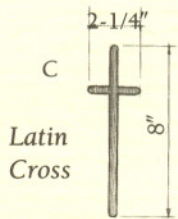

Latin Cross

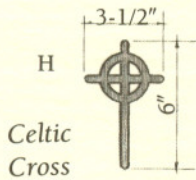

Celtic Cross

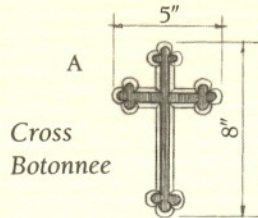

Cross Botonnee

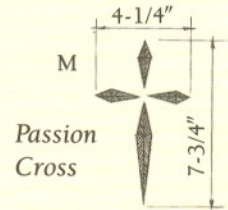

Passion Cross

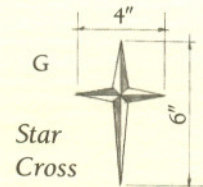

Star Cross

Book Racks

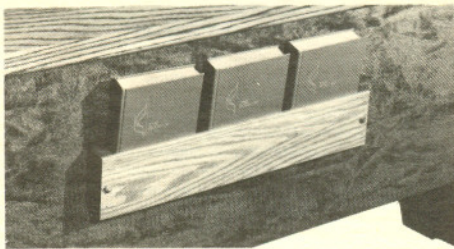

#711—3-book capacity

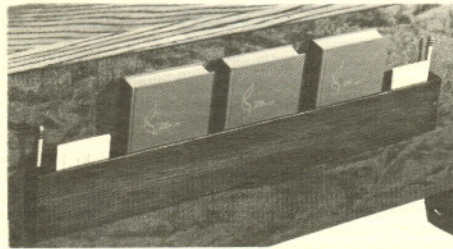

#712—3-book capacity including card & pencil holder

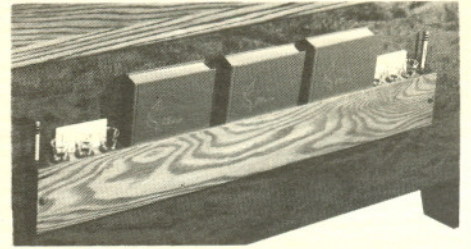

#713—3-book capacity including communion glass, card & pencil holders

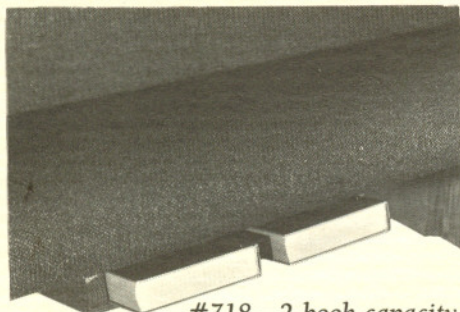

#718—2-book capacity under seat rack

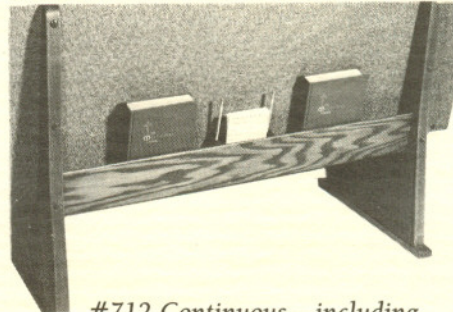

#712 Continuous—including card & pencil holder

Colonial Groupings

Chairs

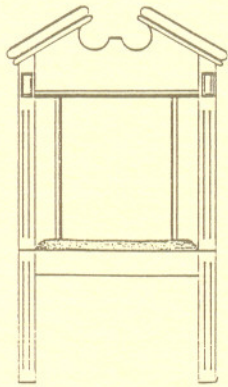

4102 — Side Chair
46" high, 22" deep, 24" wide

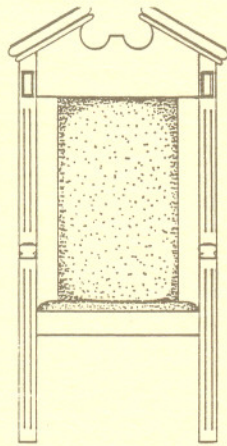

4103 — Center Chair
54" high, 22" deep, 24" wide

Ends

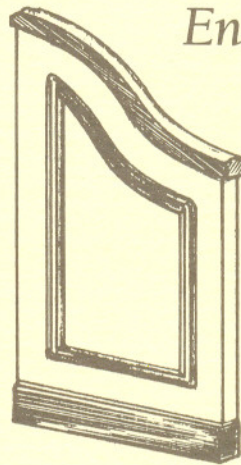

789 — End

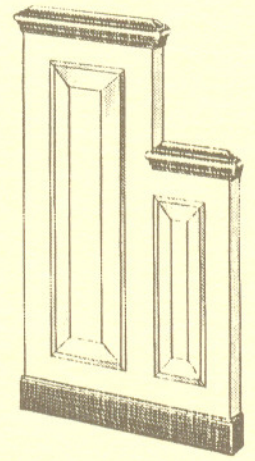

389 — End

Pulpits

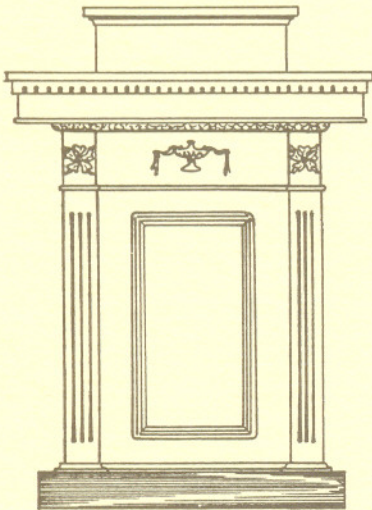

8010
Pulpit

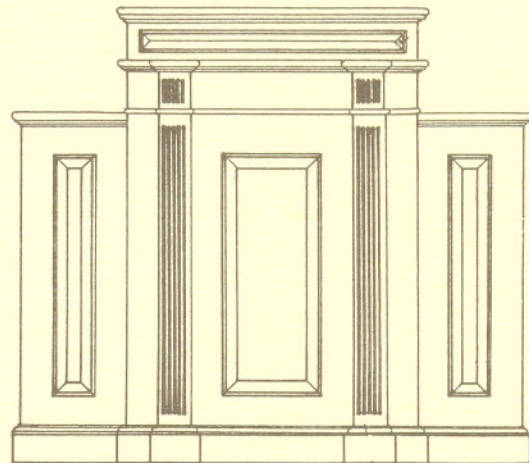

8111
Pulpit

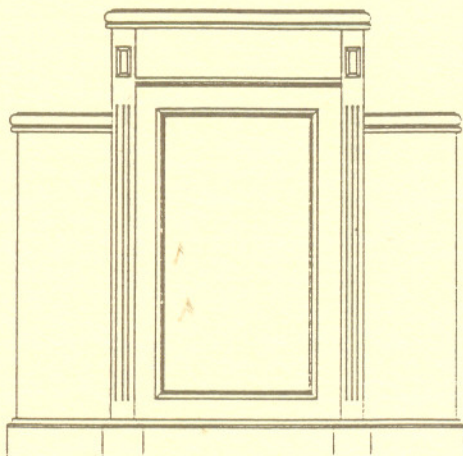

8011
Pulpit

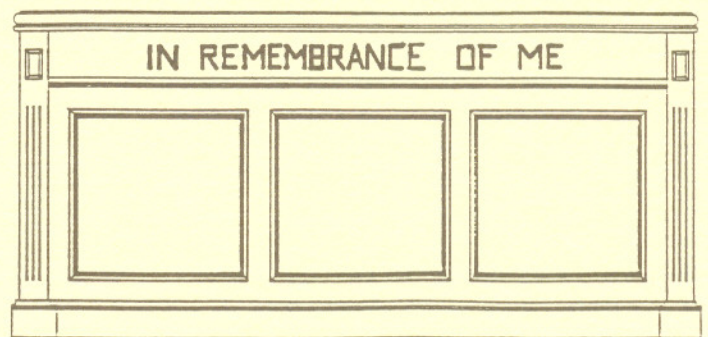

8030 — Communion Table

Anniversary Chancel Pictured

- 1230 Communion Table
- 1211 Wing Style Pulpit
- 1207 Double Prie Dieu
- 1209 Baptismal Font
- BC 200 Wall Cross
- 8103 Chancel Chair

Chancel Anniversary

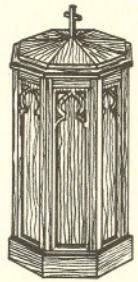

Anniversary Chancel Not Pictured

- 1240 Altar
- 1210 Pulpit
- 1221 Bay Style Pulpit
- 1212 Lectern
- 1213 Single Post Lectern
- 1217 Altar Bench
- 1215 Open Communion Rail
- 1223 Closed Chancel Rail
- 1205 Flower Stand

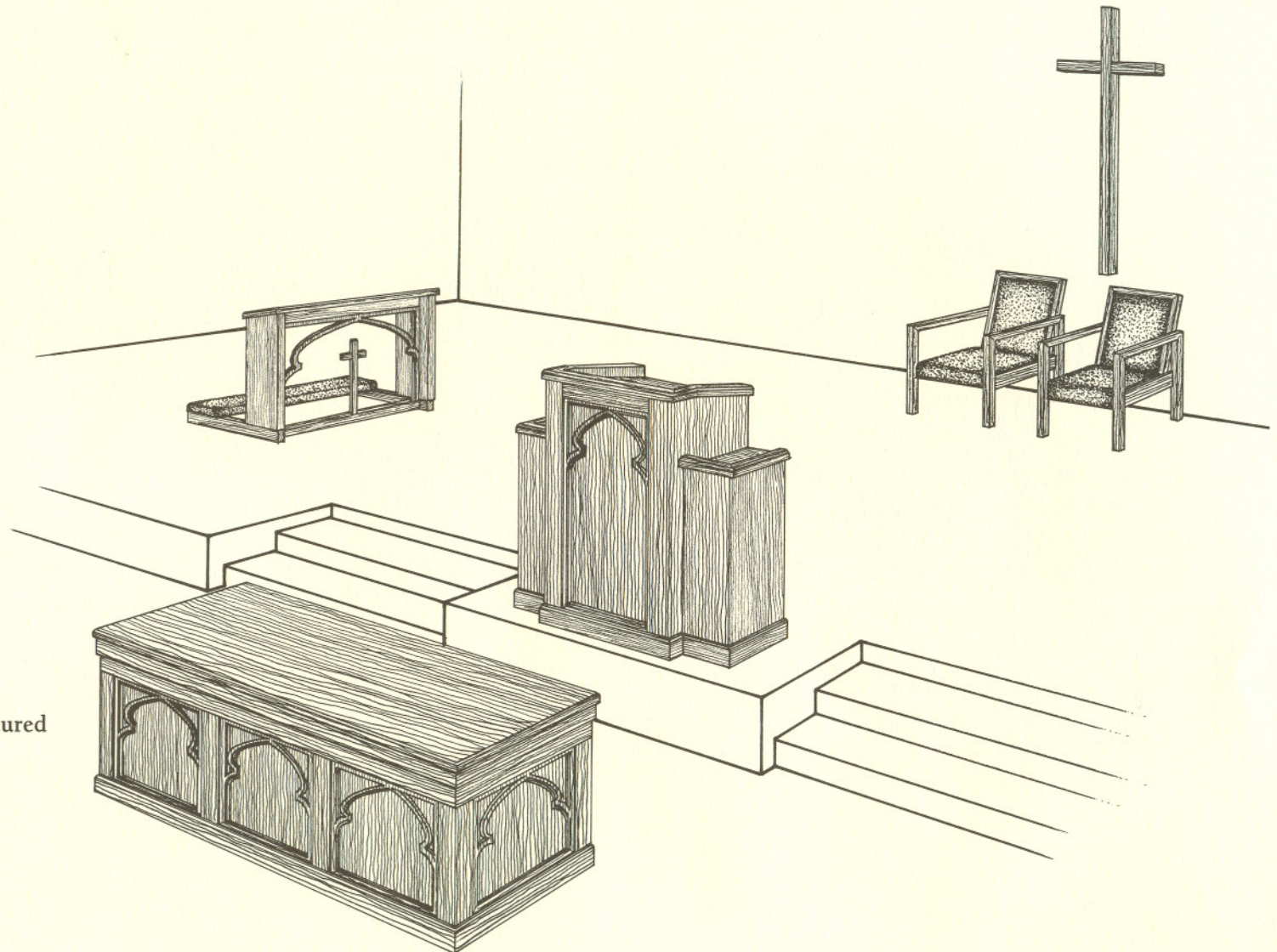

**The above illustration depicts a possible arrangement of the chancel grouping.*

Chancel Crown Royal

Crown Royal Chancel Pictured

- 1630 Communion Table
- 1611 Wing Style Pulpit
- 1612 Lectern
- 1607 Double Prie Dieu
- 1609 Baptismal Font
- 1605 Flower Stand
- 1615 Open Communion Rail (with kneelers)

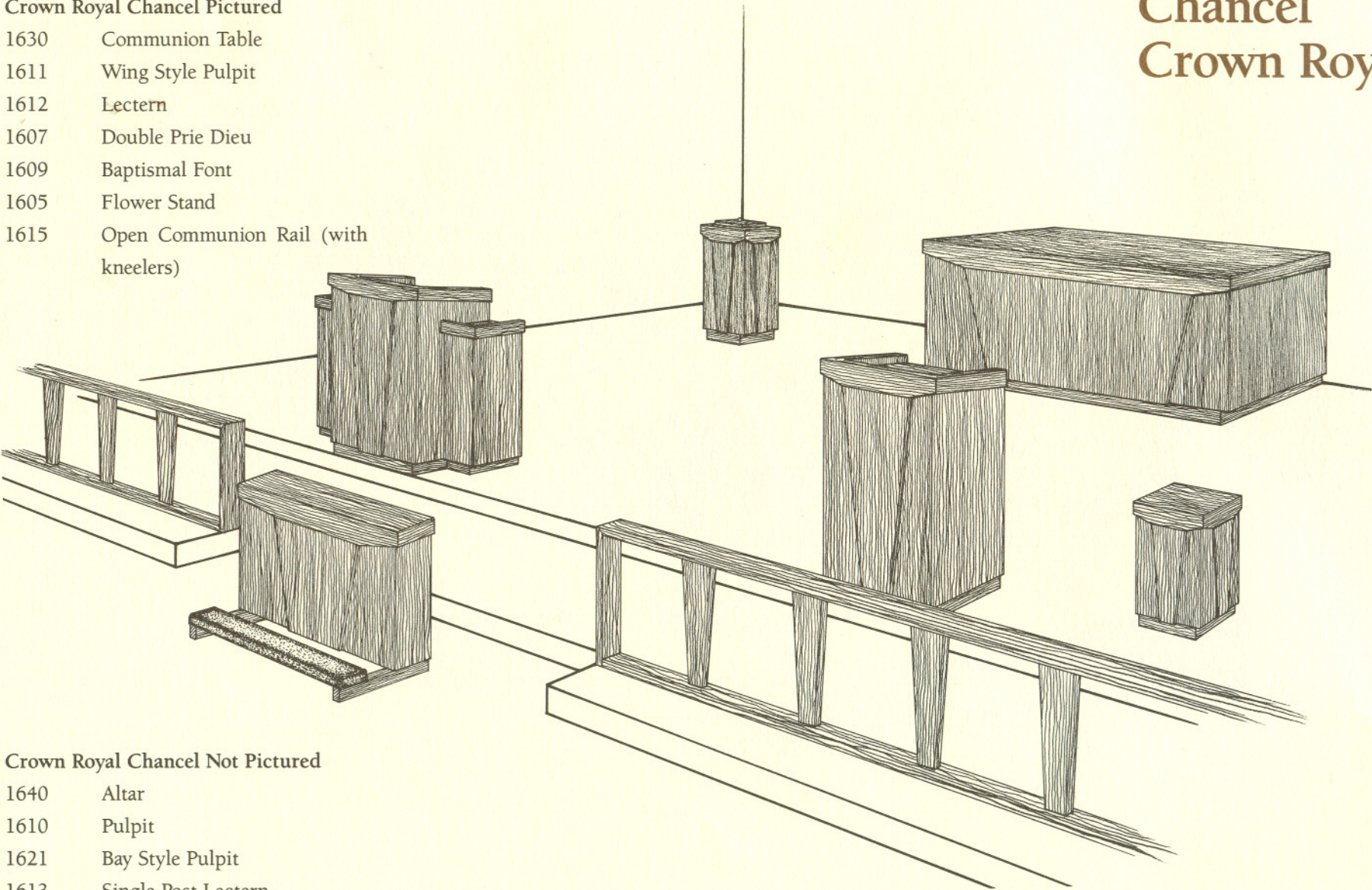

Crown Royal Chancel Not Pictured

- 1640 Altar
- 1610 Pulpit
- 1621 Bay Style Pulpit
- 1613 Single Post Lectern
- 1617 Altar Bench
- 1623 Closed Chancel Rail

**The above illustration depicts a possible arrangement of the chancel grouping.*

Concept Chancel Pictured

- 1830 Communion Table
- 1810 Pulpit
- 1807 Double Prie Dieu
- 1809 Baptismal Font
- 1805 Flower Stand
- 1823 Closed Chancel Rail

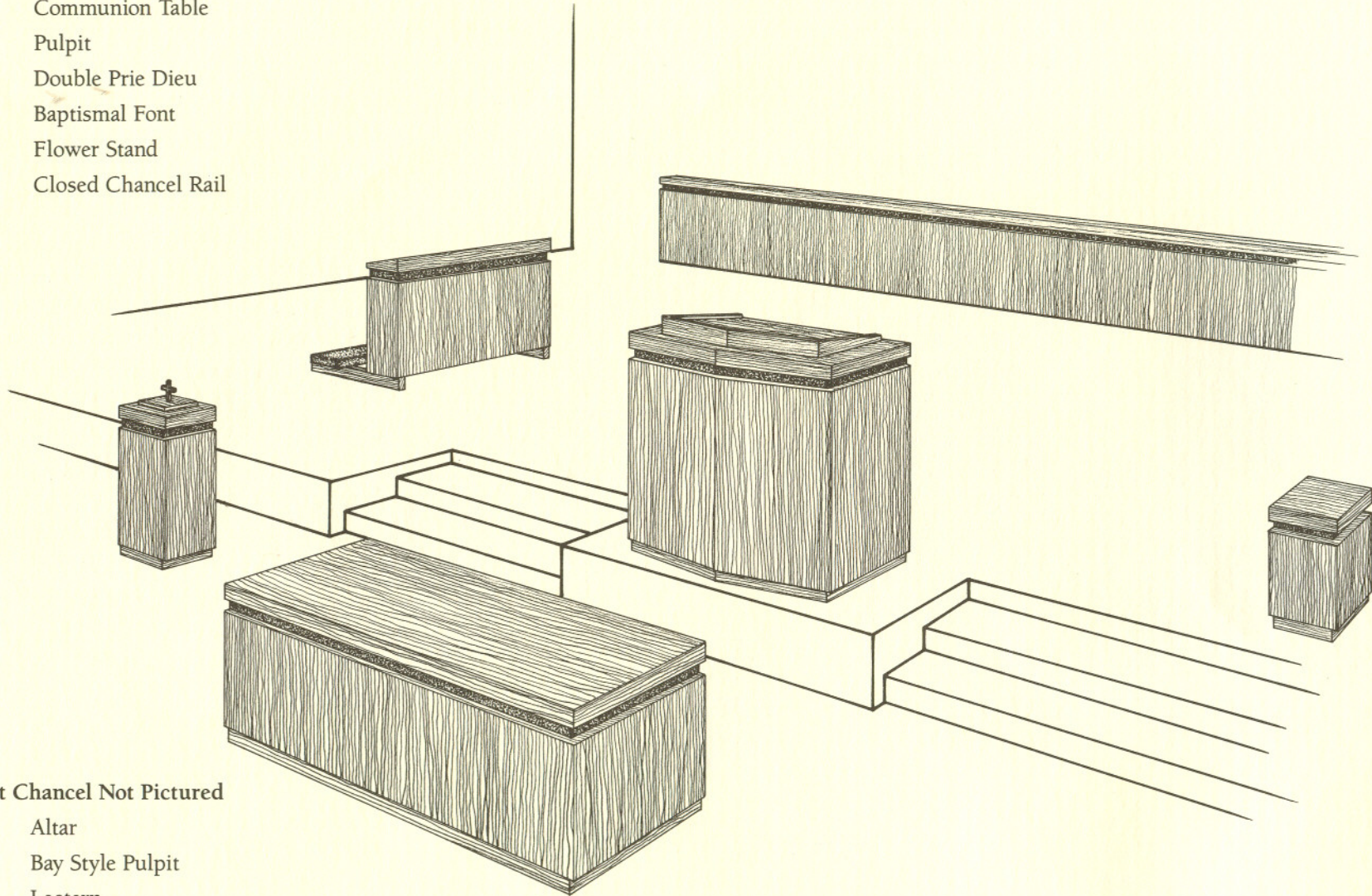

Concept Chancel Not Pictured

- 1840 Altar
- 1821 Bay Style Pulpit
- 1812 Lectern
- 1813 Single Post Lectern
- 1817 Altar Bench
- 1815 Open Communion Rail

Chancel Concept

The above illustration depicts a possible arrangement of the chancel grouping.

Chancel Heritage

Heritage Chancel Pictured

- 1330 Communion Table
- 1311 Wing Style Pulpit
- 1312 Lectern
- 1309 Baptismal Font
- 1317 Altar Bench

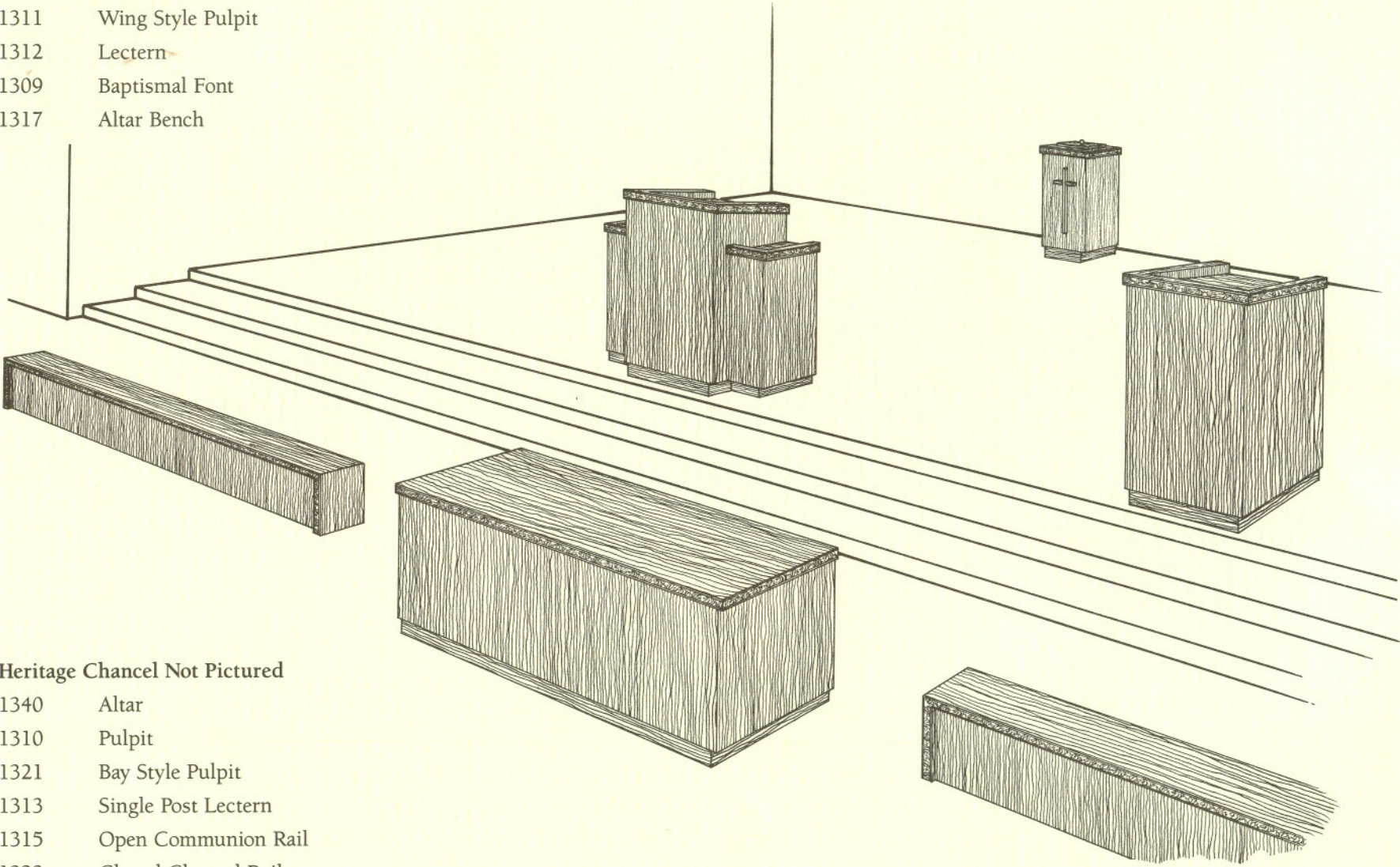

Heritage Chancel Not Pictured

- 1340 Altar
- 1310 Pulpit
- 1321 Bay Style Pulpit
- 1313 Single Post Lectern
- 1315 Open Communion Rail
- 1323 Closed Chancel Rail
- 1307 Double Prie Dieu
- 1305 Flower Stand

**The above illustration depicts a possible arrangement of the chancel grouping.*

Purity Chancel Pictured

- 4830 Communion Table
- 4811 Wing Style Pulpit
- 4807 Double Prie Dieu
- 4809 Baptismal Font
- 4805 Flower Stand
- BC200 Wall Cross
- 8103 Chancel Chair

Chancel Purity

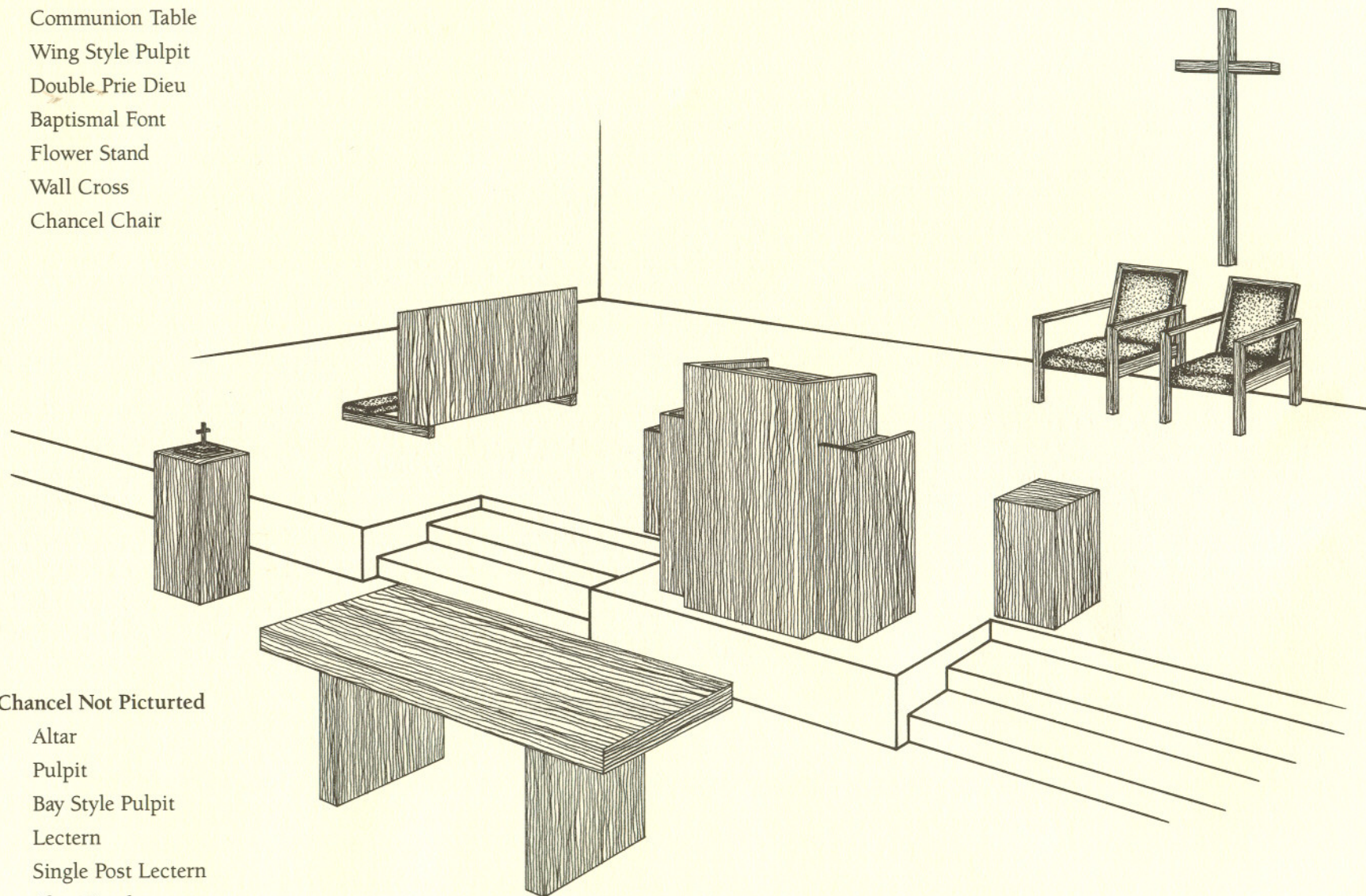

Purity Chancel Not Pictured

- 4840 Altar
- 4810 Pulpit
- 4821 Bay Style Pulpit
- 4812 Lectern
- 4813 Single Post Lectern
- 4817 Altar Bench
- 4815 Open Communion Rail
- 4823 Closed Chancel Rail

**The above illustration depicts a possible arrangement of the chancel grouping.*

Chancel Elite

Elite Chancel Pictured

- 1440 Altar
- 1411 Wing Style Pulpit
- 1412 Lectern
- 1407 Prie Dieu
- 1421 Bay Style Pulpit
- 1409 Baptismal Font
- 1415 Open Communion Rail
- 1423 Closed Chancel Rail

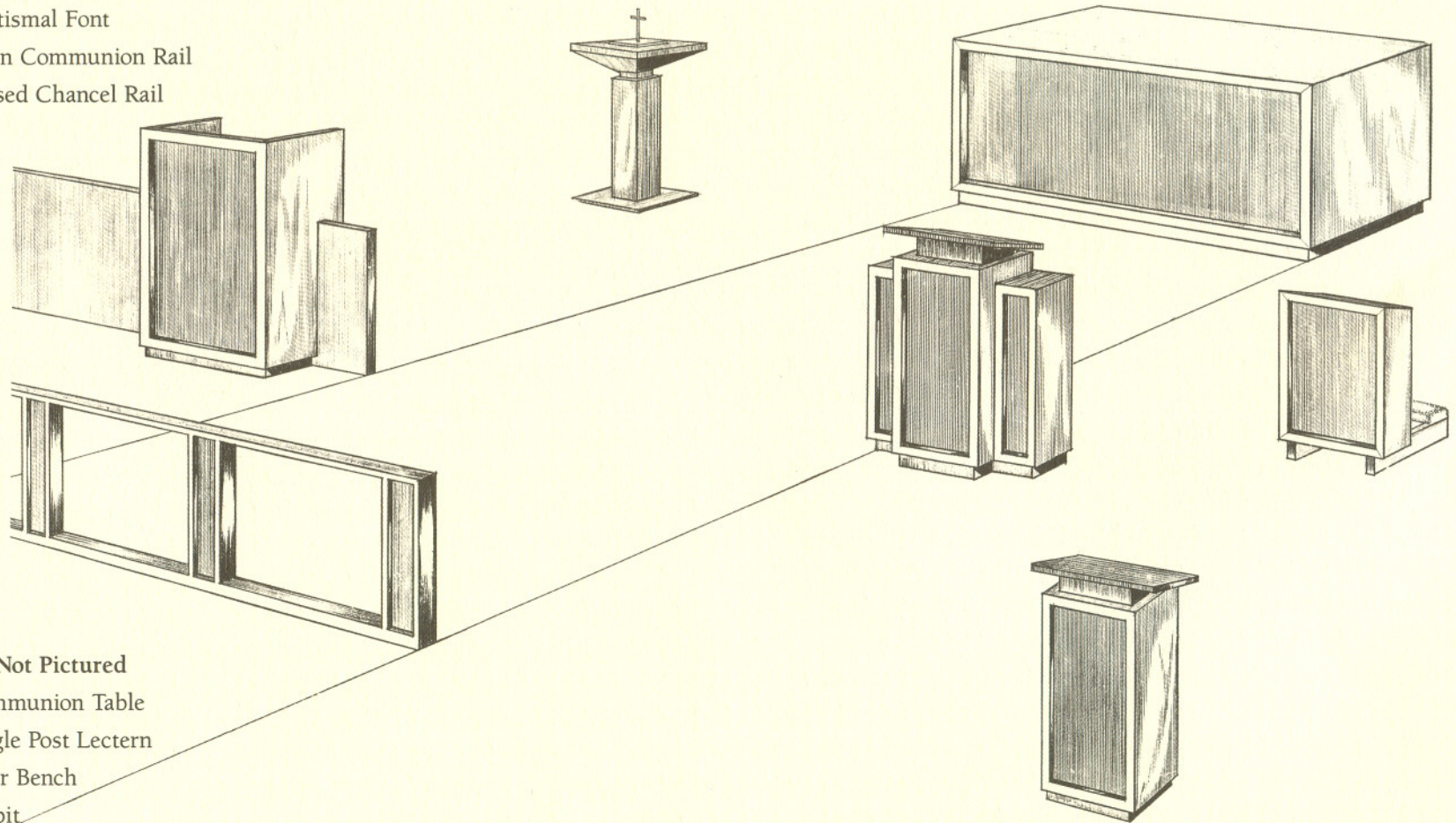

Elite Chancel Not Pictured

- 1430 Communion Table
- 1413 Single Post Lectern
- 1417 Altar Bench
- 1410 Pulpit
- 1405 Flower Stand

Contemporary Chancel Pictured

- 1540 Altar
- 1512 Lectern
- 1507 Prie Dieu
- 1521 Bay Style Pulpit
- 1509 Baptismal Font
- 1515 Open Communion Rail
- 1523 Closed Chancel Rail

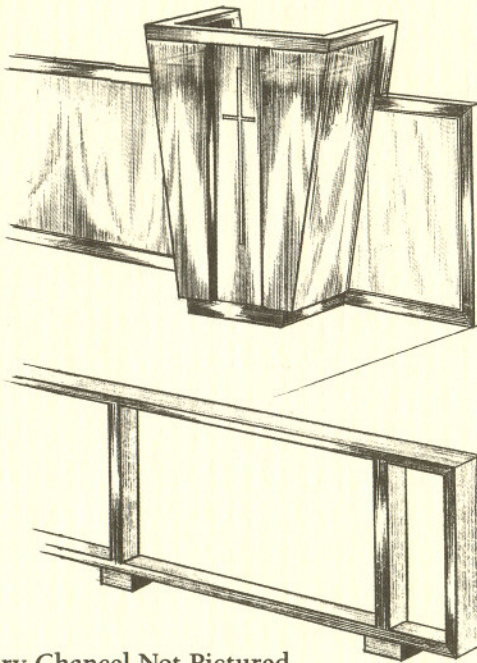

*1521 Pulpit
48" x 24" x 48"
40" x 24" x 48"
24" x 24" x 48"*

Chancel Contemporary

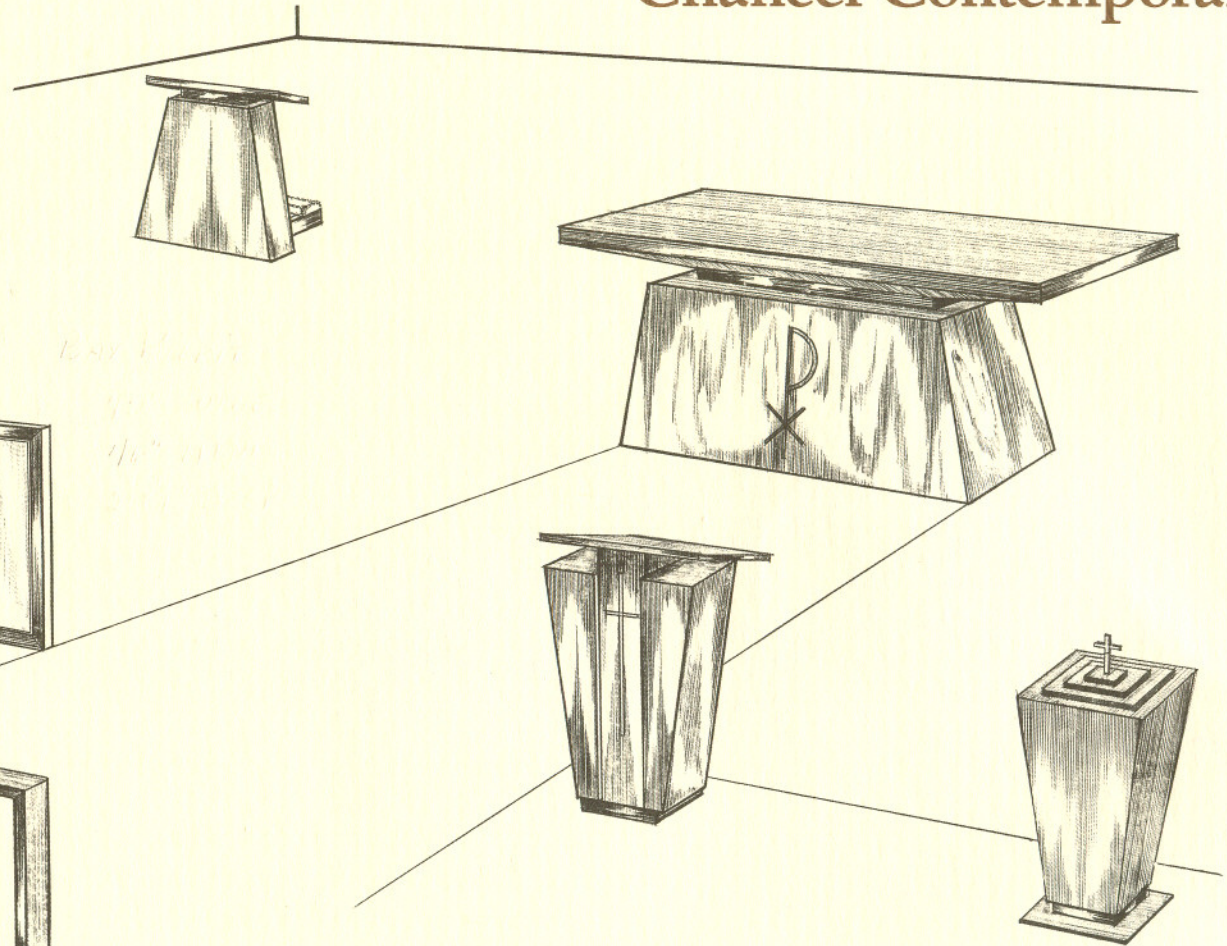

Contemporary Chancel Not Pictured

- 1530 Communion Table
- 1513 Single Post Lectern
- 1517 Altar Bench
- 1510 Pulpit
- 1505 Flower Stand
- 1511 Wing Style Pulpit

Dimensional Sheet for Chancel

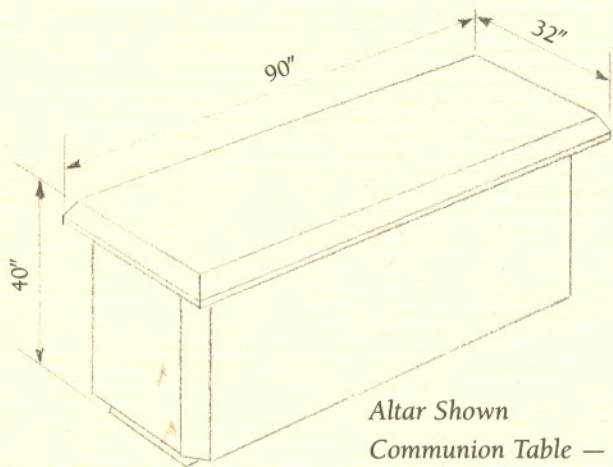
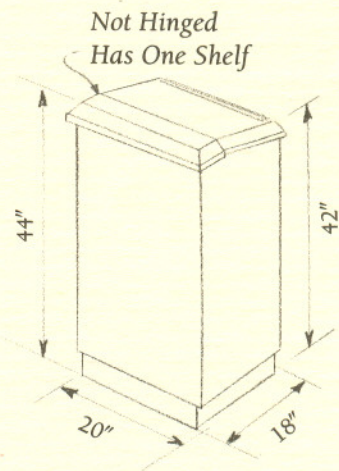
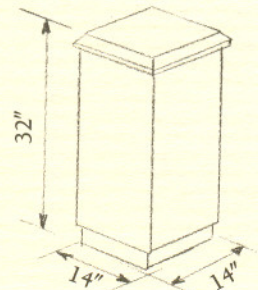
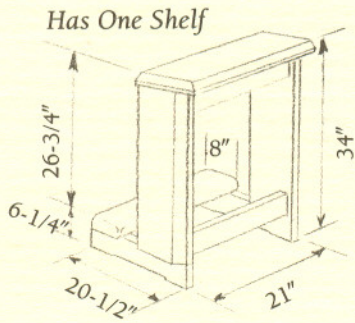
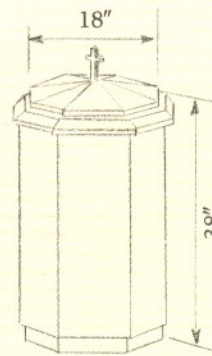
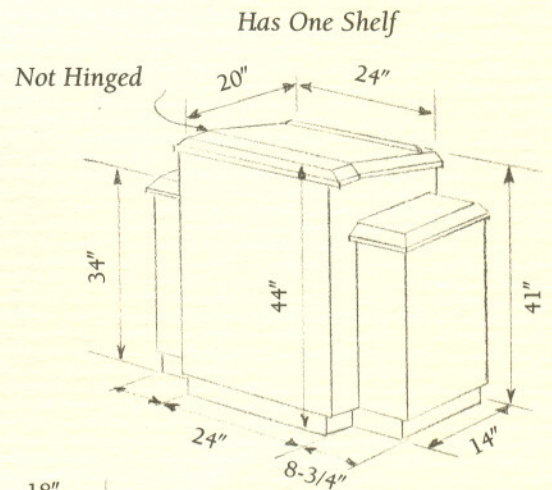
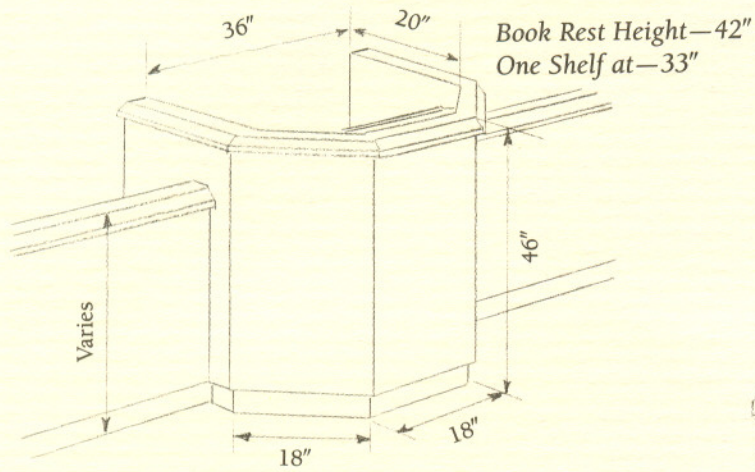

Altar Shown
Communion Table —
Length—66"
Height—32"
Width—26"

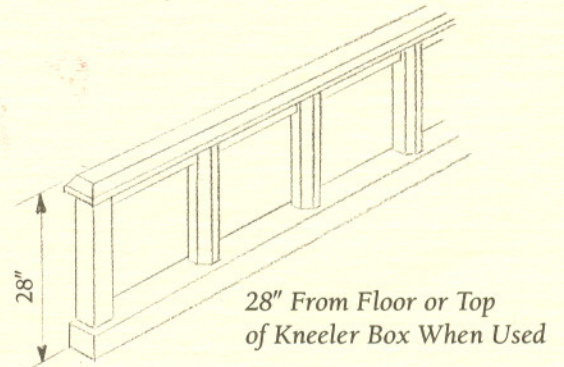

Chancel Chairs

We are pleased to offer a wide variety of styles to complement any chancel style you choose. All chairs are crafted for comfort and sturdiness and only the finest red oak is used in their construction.

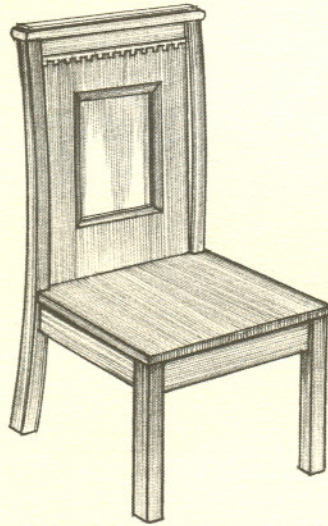

6102—24" wide, 42" high

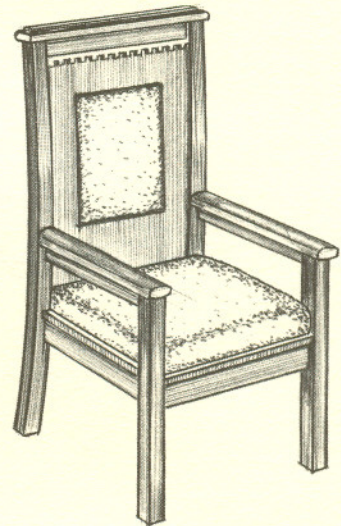

6103—24" wide, 42" high

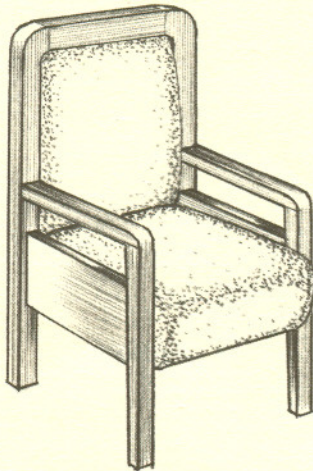

5103—24" wide, 42" high

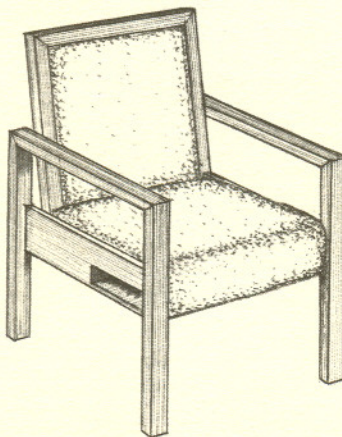

8103—24" wide, 36" high

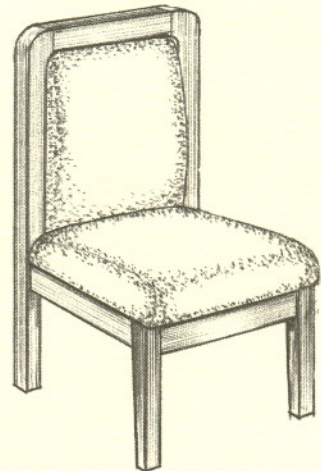

5102—24" wide, 42" high

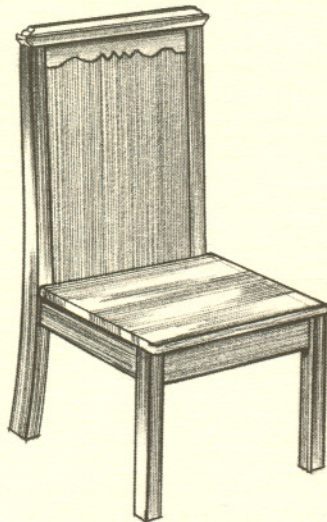

2102—24" wide, 42" high

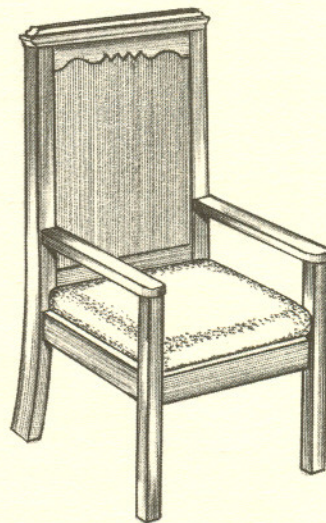

2103—24" wide, 42" high

Wall Crosses

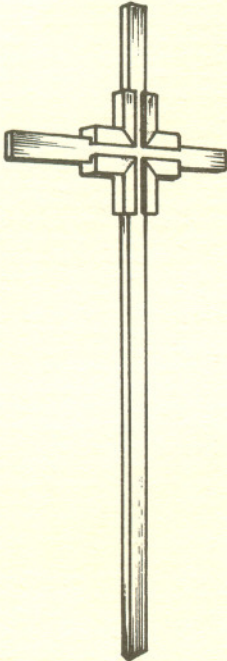

101

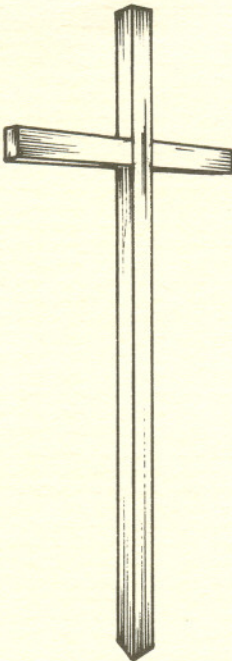

BC 200

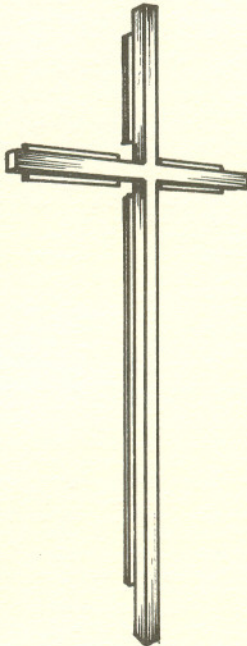

300

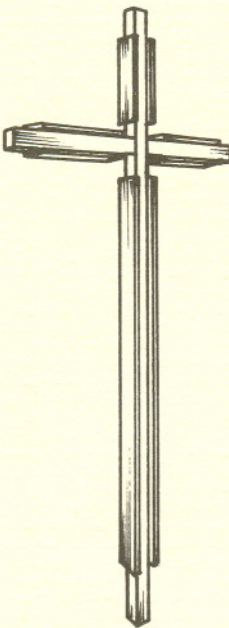

HC46

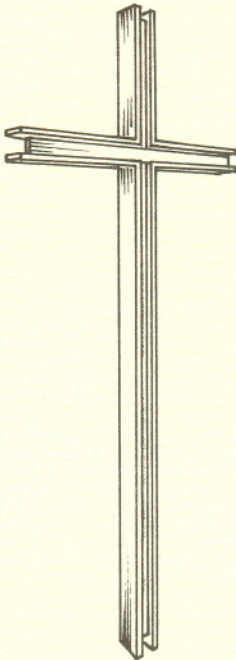

400

Back lights for crosses available. Additional cross designs available.

Frontal Screens

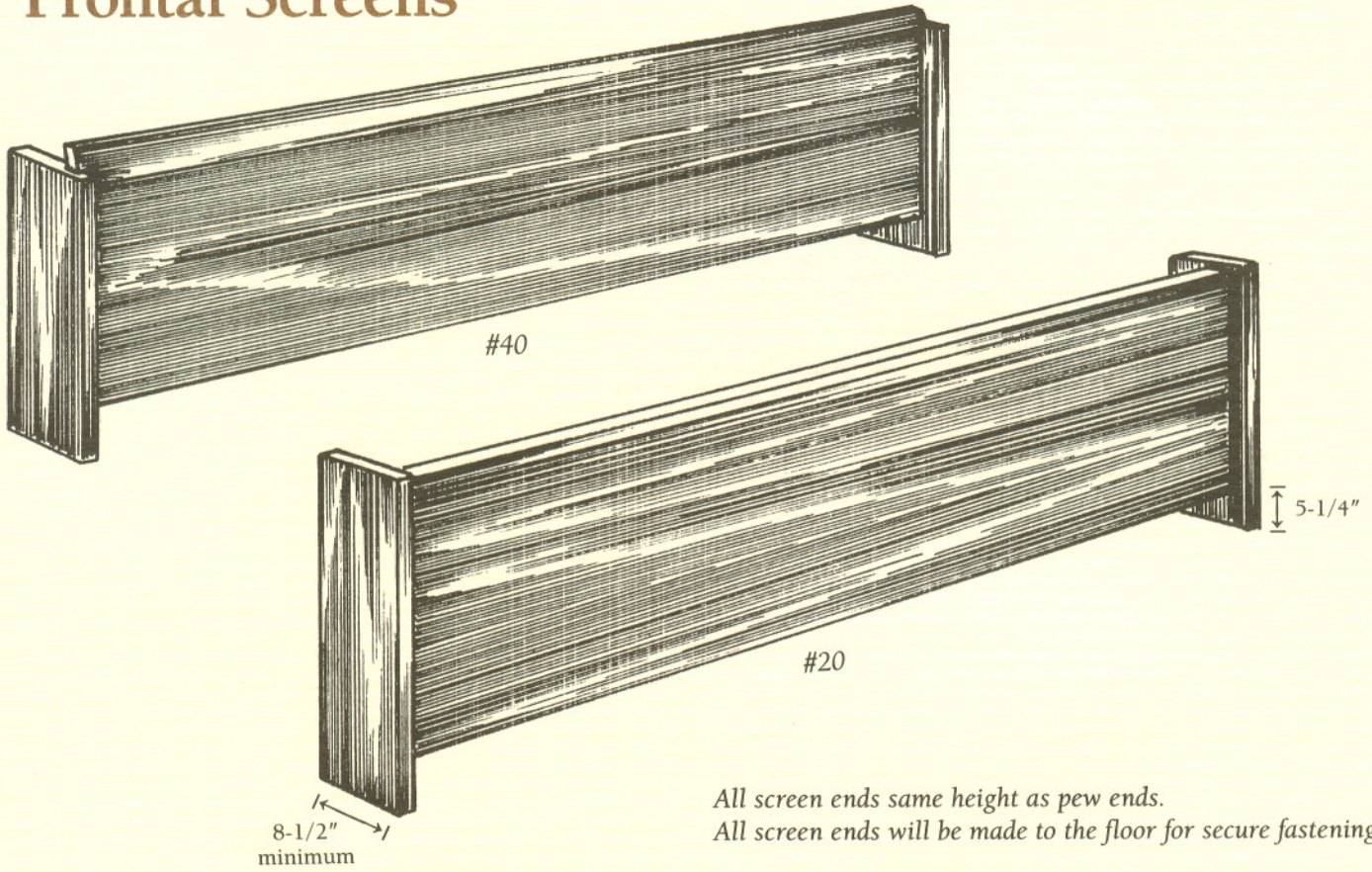

Altar Benches

Altar Benches can be made to match any series Chancel furniture

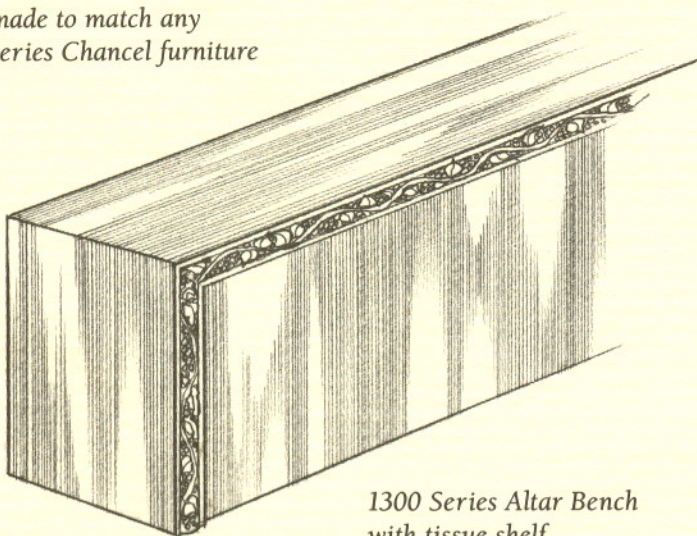

1300 Series Altar Bench
with tissue shelf
17" high, 12" deep

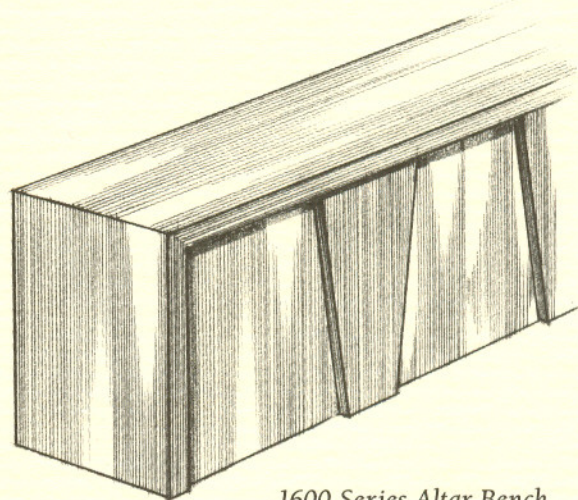

1600 Series Altar Bench
with tissue shelf
17" high, 12" deep

Accessories

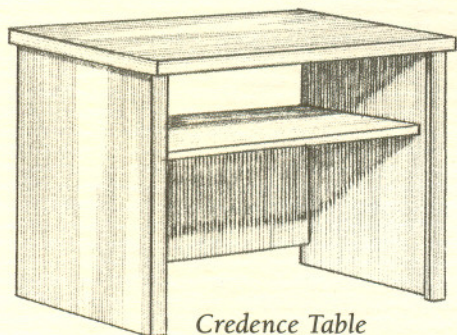

Credence Table
32" high, 40" wide, 18" deep

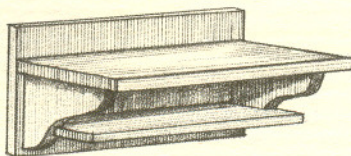

Credence Shelf
8" high, 20" wide, 14" deep

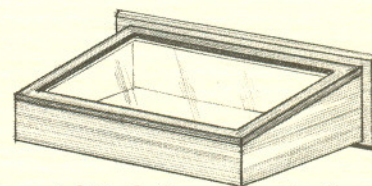

Memorial Book Repository (wall mounted)
6" high, 20" wide, 16" deep

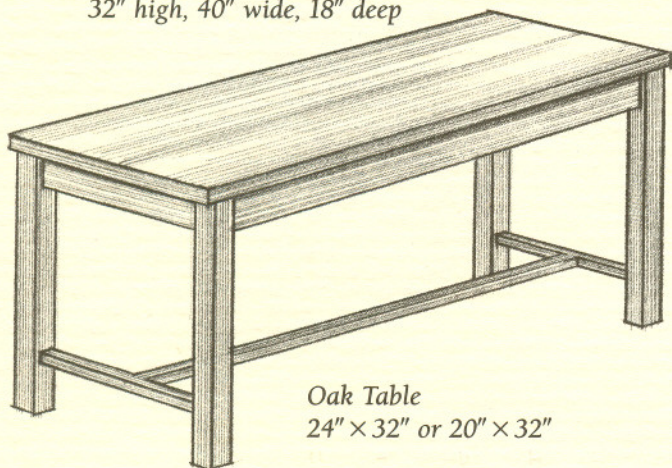

Oak Table
24" x 32" or 20" x 32"

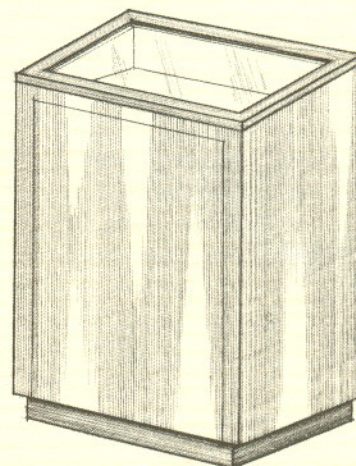

Memorial Book Repository (free standing)
40" high, 24" wide, 16" deep

Narthex Benches

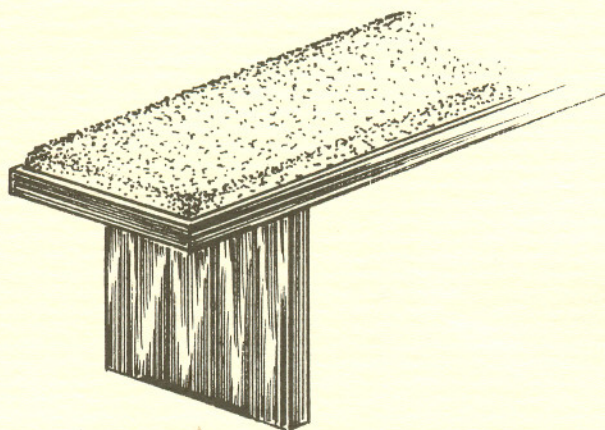

Cantilevered End Style

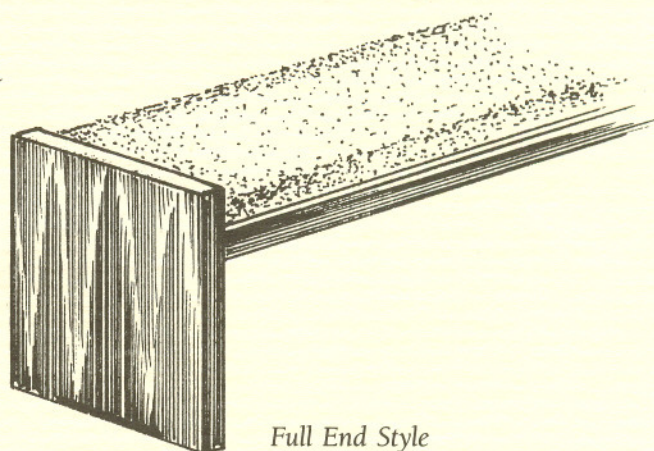

Full End Style

The Marshall Company

Since 1936, The Marshall Company - owned and operated by a dedicated Methodist family, has made personal service and quality furniture a family heritage.

Now, with a second generation at the helm, The Marshall Company remains proud of its commitment to excellence. We remain close to our roots — in service, in craftsmanship and in location.

Our home base is located near two all weather highways in Payette, Idaho — a spectacular state noted for its high quality of life and panoramic beauty. Our transportation fleet enables us to maintain our exceptional location and provide efficient delivery throughout the nation.

By air or land, The Marshall Company strives for the quickest possible response to our customers needs. To do our best is a charge we grew up with. We'll never take it lightly.

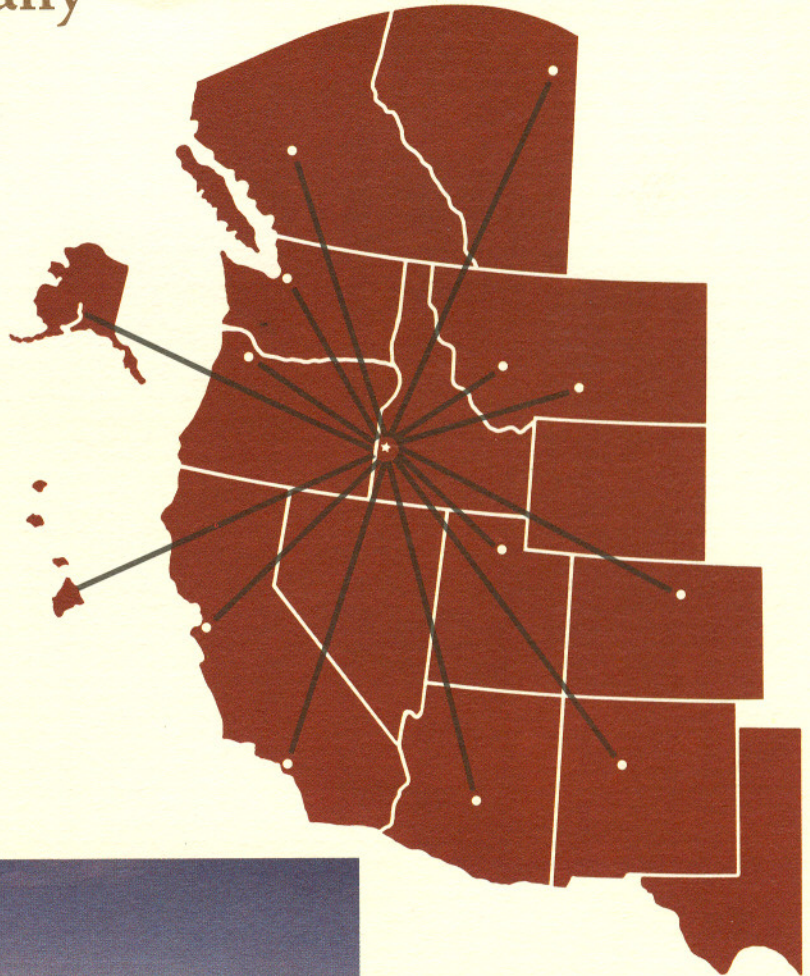

THE MARSHALL CO.
620 N. 9TH STREET
P.O. BOX 700
PAYETTE, IDAHO 83661
PHONE: (208) 642-3344
TOLL FREE: (800) 635-9026

